

HPS Spartan and HPS Fusion - Wiring Schematic Drawings

Group A

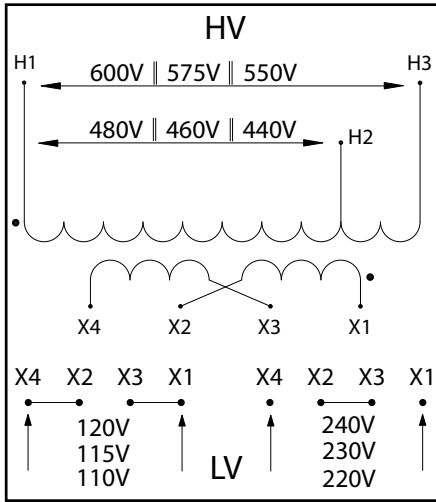

SP*ACP Schematic Connections for 600/480 to 120 X 240**

FS*ACP Schematic Connections for 600/480 to 120 X 240**

High Voltage (HV) (Primary Volts)	Install Supplied Jumpers Between Terminals	Supply Lines Connect To
600 575 550	None	H1, H3
480 460 440	None	H1, H2

Low Voltage (LV) (Secondary Volts)	Install Supplied Links Between Terminals	Load Lines Connect To
120 115 110	X1-X3, X2-X4	X1, X4
240 230 220	X2-X3	X1, X4

Group B

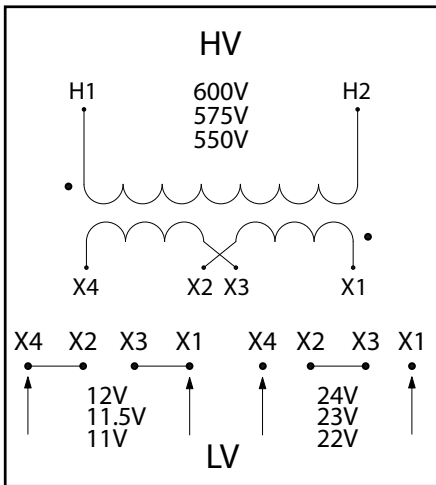

SP*AR Schematic Connections for 600/480 to 12 X 24**

FS*AR Schematic Connections for 600/480 to 12 X 24**

High Voltage (HV) (Primary Volts)	Install Supplied Jumpers Between Terminals	Supply Lines Connect To
600 575 550	None	H1, H2

Low Voltage (LV) (Secondary Volts)	Install Supplied Links Between Terminals	Load Lines Connect To
12 11.5 11	X1-X3, X2-X4	X1, X4
24 23 22	X2-X3	X1, X4